

Biblis

Avio Calandrin, Eugenio Farina



true



The Biblis collection is characterized by aesthetic connotations typical of the home environment transferred to the contract, combining the warmth of home with the minimalistic language of the public space.

The result is a timeless shape, adaptable to the flexibility of the modern working and domestic environment. The shrinkage of the backrest welcomes the user, developing a visual feeling made of comfort and softness. The metal feet define the connection between the seat and the standing surface, providing also an optimal accessibility for the cleaning operations.

La serie di sedute Biblis si caratterizza per la presenza di valori estetici derivati dall'ambiente Home trasferiti al settore contract, fondendo il calore della casa con il linguaggio minimalista tipico dello spazio pubblico.

Il risultato è una forma senza tempo, che si può adattare ad ambienti dalle molteplici destinazioni d'uso e coordinate estetiche. Il restringimento della parte posteriore invita alla seduta, costruendo un feeling visivo all'insegna della comodità e dell'accoglimento. Il piedino distingue la relazione visiva con le superfici di appoggio, garantendo inoltre una ottimale accessibilità per le operazioni di igiene e pulizia delle stesse.



true



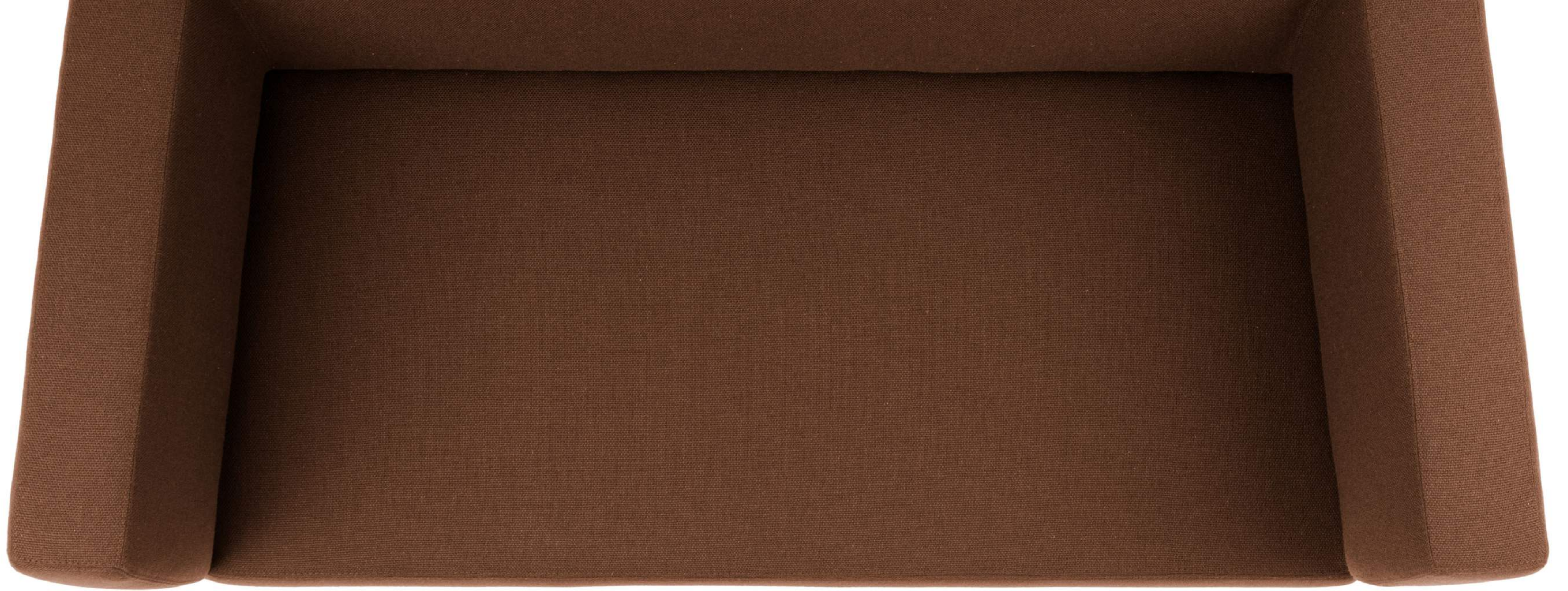







VARIANTS
Varianti

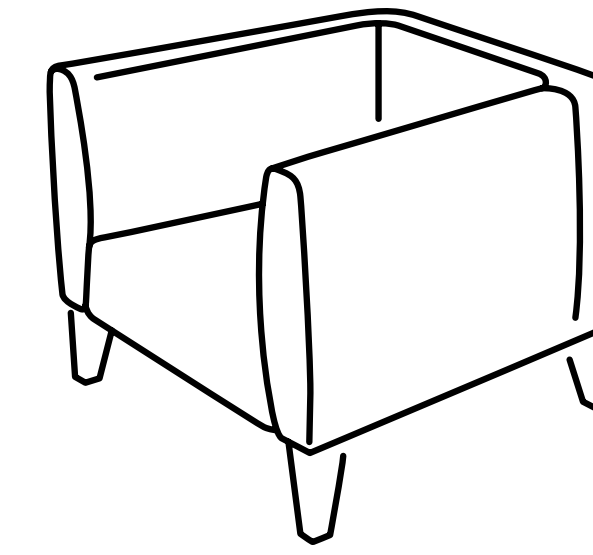

BB 1000
W92 · D76 · H74

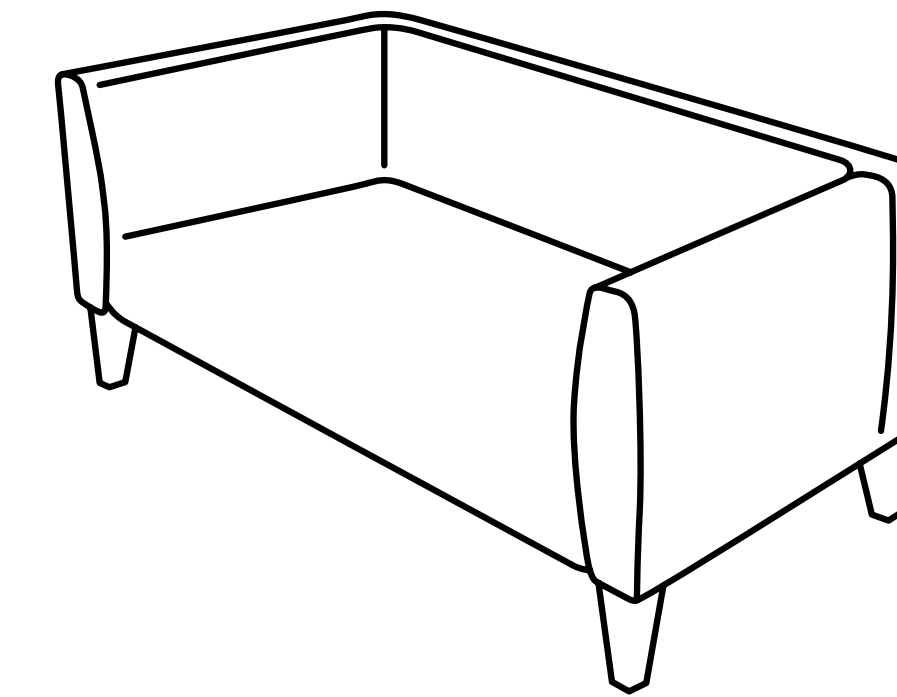

BB 2000
W146 · D76 · H74

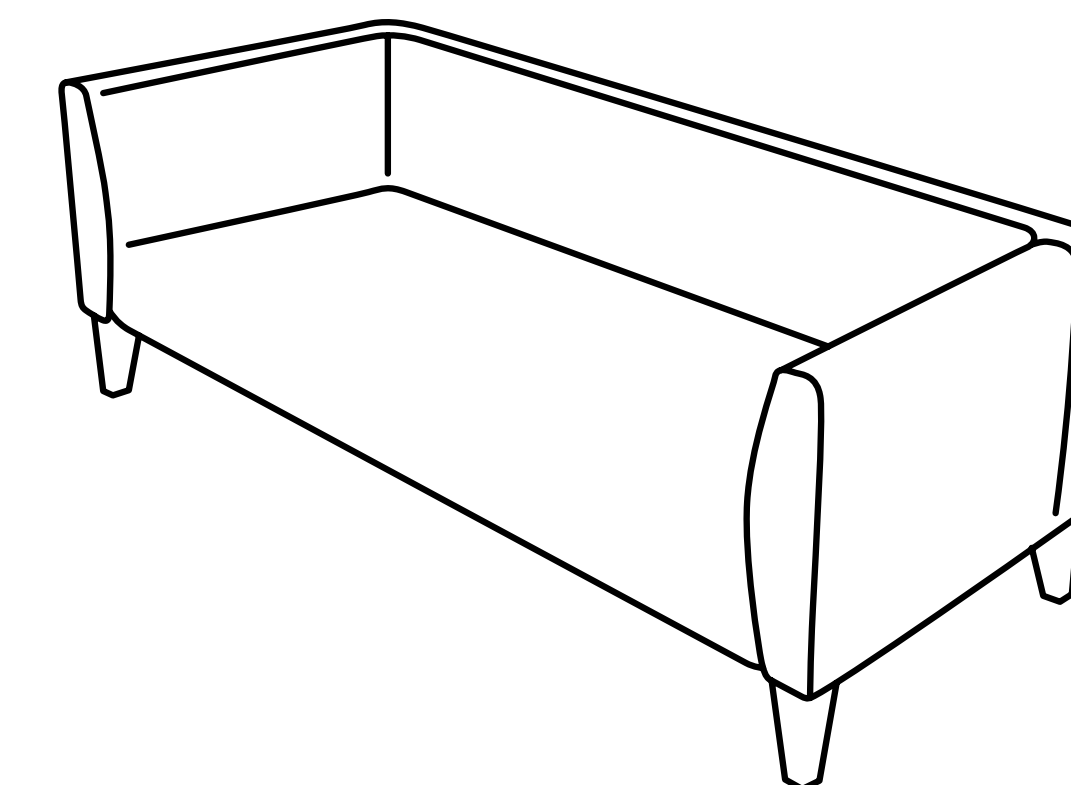

BB 3000
W205 · D76 · H74

true

True Design s.r.l.

Via Leonardo Da Vinci 2 - 35040 Sant'Elena (PD) Italy
Tel. +39 0429 692483 - info@truedesign.it - www.truedesign.it