

WING

Parisotto+Formenton

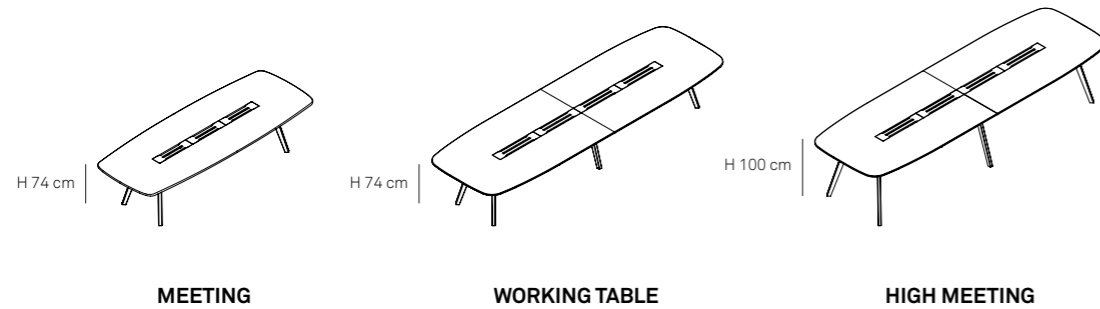

COLORS AND MATERIALS COLORI E MATERIALI - COULEURS ET MATÉRIAUX

TABLE TOP PIANO DEL TAVOLO - PLATEAU

WOODEN TOP PIANO IN LEGNO PLATEAU EN BOIS



oakwood
rovere - chêne

walnut
noce - noyer

FULL CORE WHITE HPL TOP PIANO IN HPL FULL CORE BIANCO HPL FULL CORE BLANC



white
bianco - blanc

BLACK/DECORATED HPL TOP PIANO IN HPL DECORATO/NERO PLATEAU EN HPL NOIR/DÉCORÉ



natural oak 0125

cognac oak 0048

PLYWOOD TOP PIANO IN MULTISTRATO PLATEAU EN CONTREPLAQUÉ



white
bianco - blanc

Arpa 4520 oakwood

LEGS GAMBE - PIEDS

oakwood
rovere - chêne

walnut
noce - noyer

beechwood
faggio - hêtre

steel
acciaio - acier

BEAM TRAVE - POUTRE

9005
black

9010
white

TECHNICAL FEATURES SPECIFICHE TECNICHE - SPÉCIFICATIONS TECHNIQUES

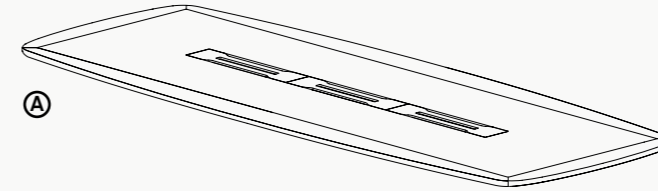

Wooden top, made of 40mm thick veneer on MDF (30mm for 220 version); solid wood edges.

Piano in legno, costituito da struttura interna in MDF 40mm (30mm per la versione 220); bordo perimetrale in legno massello.
Plateau en bois, en MDF de 40mm d'épaisseur (30mm pour la version 220), recouvert de placage; chants en bois massif.

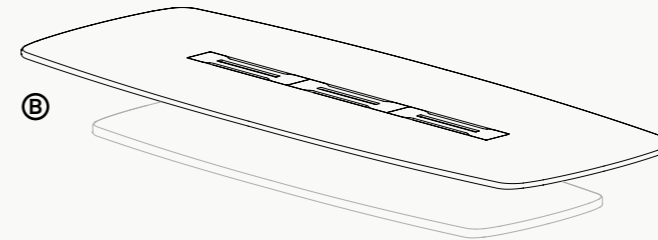

HPL top, white full core, 12mm thick, installed on a 30mm thick lacquered MDF support.

Piano in HPL, full core bianco, spessore 12mm, installato su un supporto in MDF laccato 30mm.
Plateau en HPL, âme pleine blanche, épaisseur 12mm, installé sur un support en MDF de 30mm d'épaisseur.

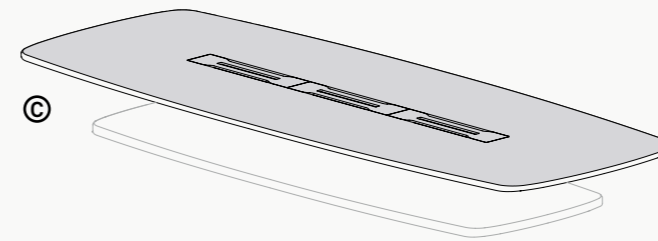

Decorated HPL top, 12mm thick, installed on a 30mm thick MDF support.

Piano in HPL decorato, spessore 12mm, installato su un supporto in MDF spessore 30mm.
Plateau HPL décoré de 12 mm d'épaisseur, posé sur un support MDF de 30mm d'épaisseur.

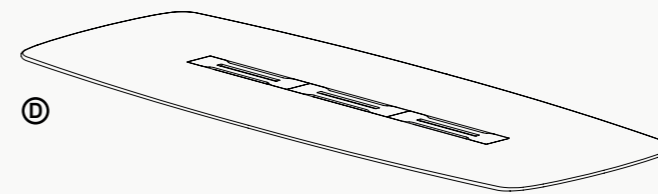

Top in birch plywood 22mm thick with 9/10 laminate finishing on both sides.

Piano in multistrato ligneo di betulla spessore 22mm con finitura in laminato da 9/10 su entrambi i lati.
Plateau en contreplaqué de bouleau 22mm d'épaisseur avec finition stratifiée de 9/10 sur deux faces.

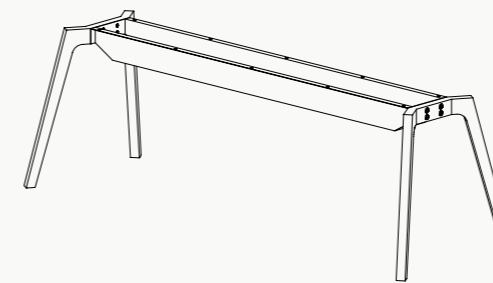
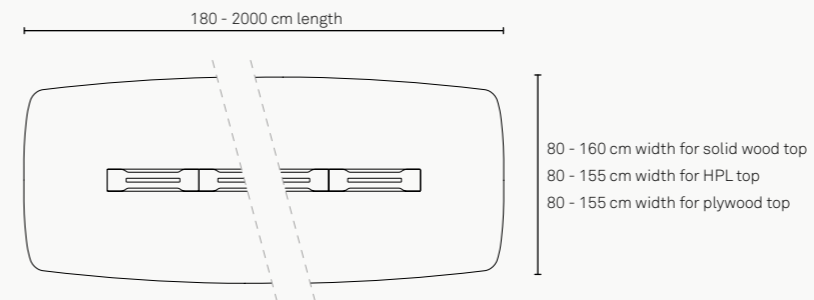

Table top installed on a steel beam fixed to solid wood legs or to steel legs.

Piano del tavolo montato su trave in acciaio fissata a gambe in legno massello o d'acciaio.
Plateau de table installé sur une poutre en acier fixée sur des pieds en bois massif ou en acier.



Custom sized tops are available on request.

Piani in dimensioni custom sono disponibili su richiesta.
Plateaux aux dimensions personnalisées sont disponibles sur demande.

true

MEETING

WI 220
table 220x110x74 cm
tavolo 220x110x74 cm
table 220x110x74 cm

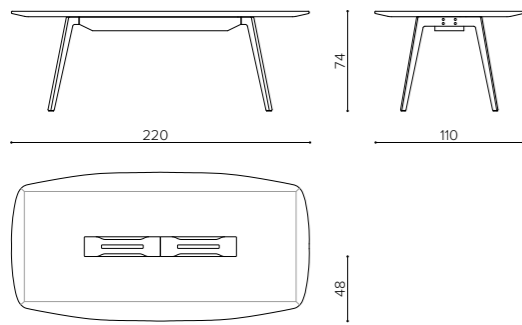

kg 60 mc 1,79

WI 320
table 320x120x74 cm
tavolo 320x120x74 cm
table 320x120x74 cm

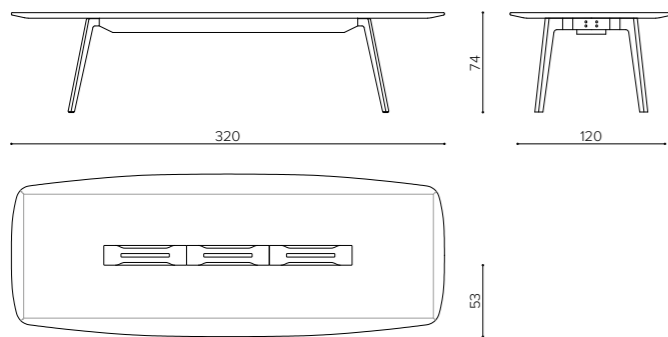

kg 72 mc 2,8

WI 450
table 450x140x74 cm
tavolo 450x140x74 cm
table 450x140x74 cm

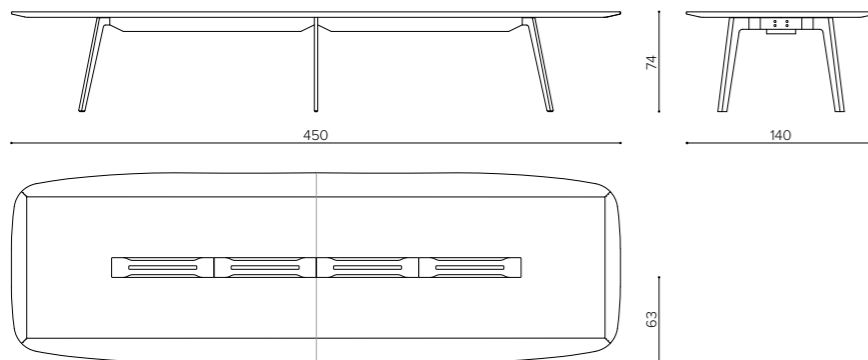

kg 126 mc 4,6

HIGH MEETING

WI 220H
high table 220x110x100 cm
tavolo alto 220x110x100 cm
table haute 220x110x100 cm

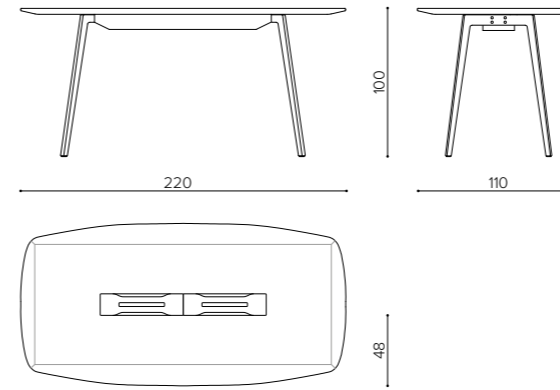

kg 60 mc 2,42

WI 320H
high table 320x120x100 cm
tavolo alto 320x120x100 cm
table haute 320x120x100 cm

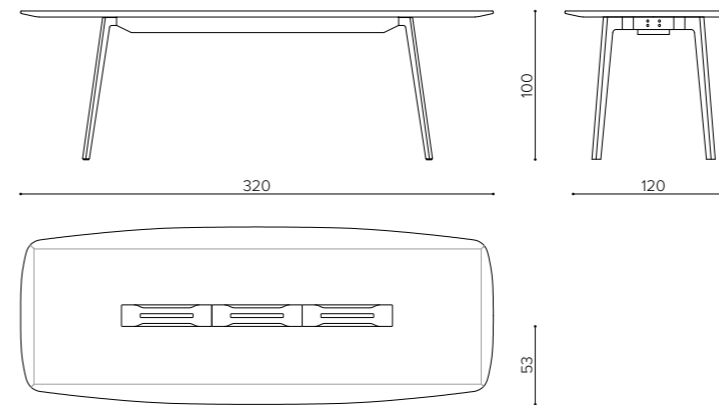

kg 72 mc 3,8

WI 450H
high table 450x140x100 cm
tavolo alto 450x140x100 cm
table haute 450x140x100 cm

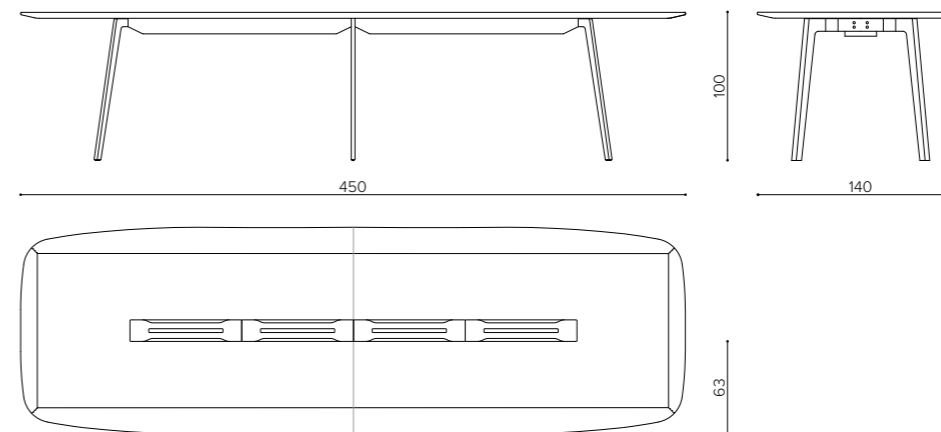

kg 126 mc 6,3

WORKING TABLE

WI 180

Laminate top, solid beechwood legs - 180x110 cm

Piano laminato, gambe in legno massello di faggio
Plateau stratifiée, pieds en hêtre massif

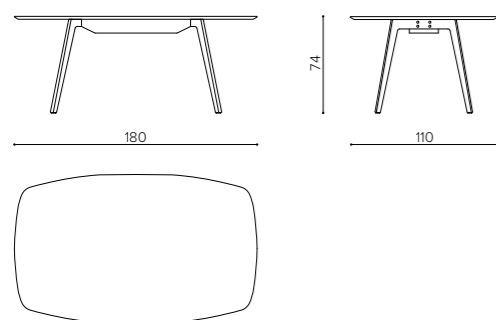

kg 60 mc 1,4

WI 240

Laminate top, solid beechwood legs - 240x120 cm

Piano laminato, gambe in legno massello di faggio
Plateau stratifiée, pieds en hêtre massif

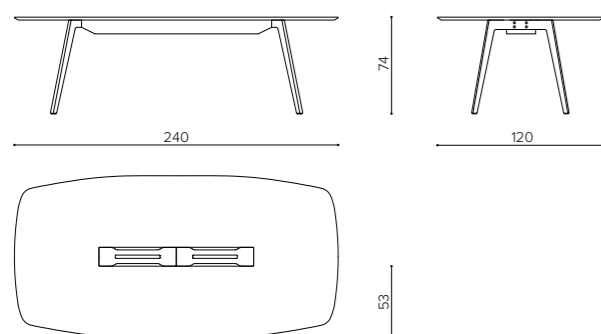

kg 72 mc 2,1

WI 300

Laminate top, solid beechwood legs - 300x140 cm

Piano laminato, gambe in legno massello di faggio
Plateau stratifiée, pieds en hêtre massif

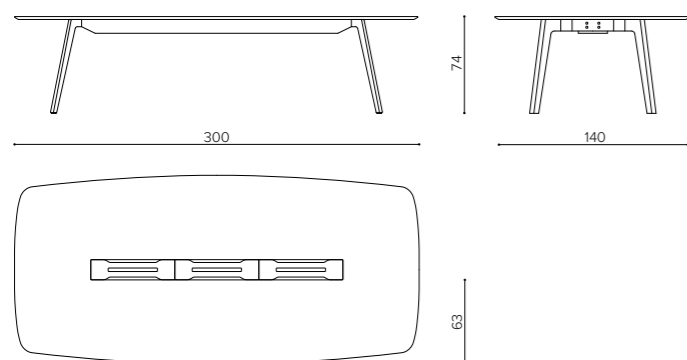

kg 126 mc 3,1

WI 420

Laminate top, solid beechwood legs - 420x150 cm

Piano laminato, gambe in legno massello di faggio
Plateau stratifiée, pieds en hêtre massif

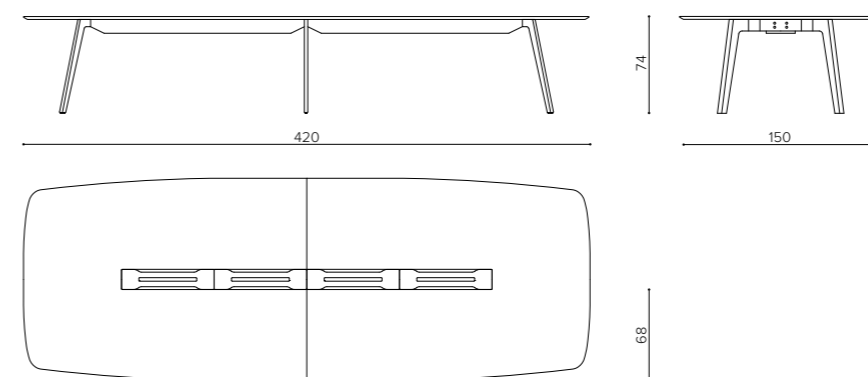

kg 140 mc 4,9

WI 500

Laminate top, solid beechwood legs - 500x150 cm

Piano laminato, gambe in legno massello di faggio
Plateau stratifiée, pieds en hêtre massif

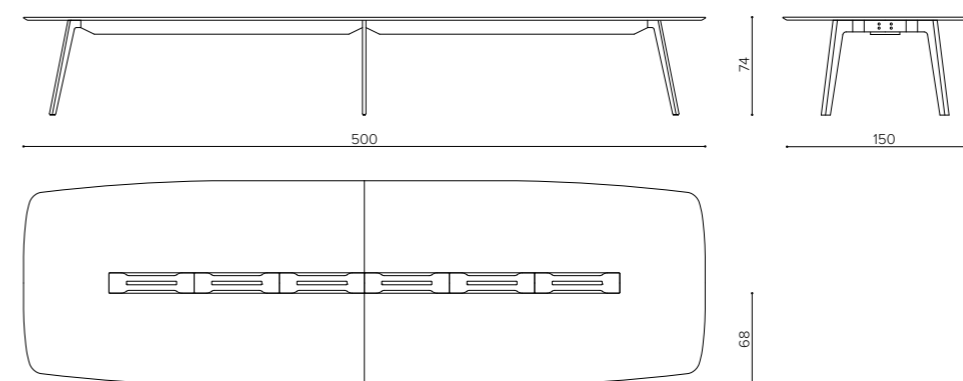

HIGH WORKING TABLE

WI 180H
high table 180x110x100 cm
tavolo alto 180x110x100 cm
tavolo haute 180x110x100 cm

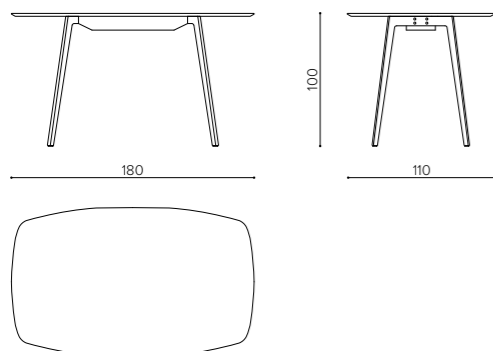

kg 60 mc 1,9

WI 240H
high table 240x120x100 cm
tavolo alto 240x120x100 cm
tavolo haute 240x120x100 cm

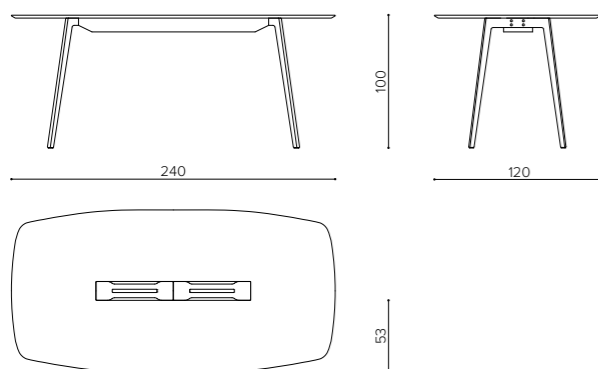

kg 72 mc 2,8

WI 300H
high table 300x140x100 cm
tavolo alto 300x140x100 cm
tavolo haute 300x140x100 cm

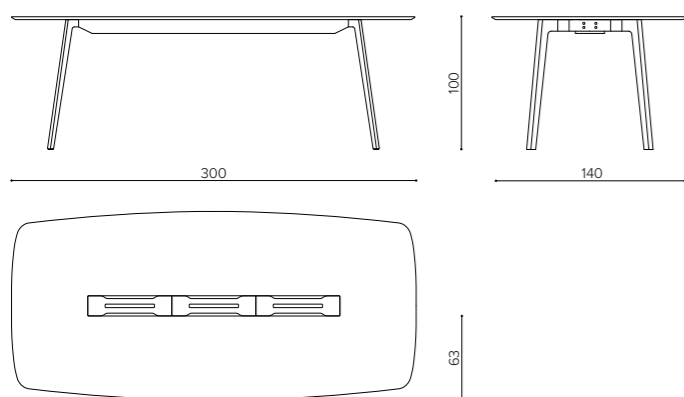

kg 126 mc 4,2

WI 420H
high table 420x150x100 cm
tavolo alto 420x150x100 cm
tavolo haute 420x150x100 cm

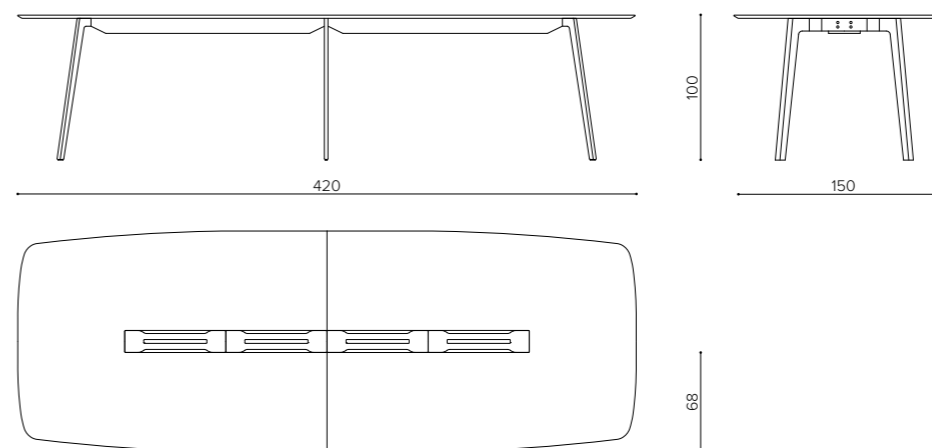

kg 140 mc 6,3

WI 500H
high table 500x150x100 cm
tavolo alto 500x150x100 cm
tavolo haute 500x150x100 cm

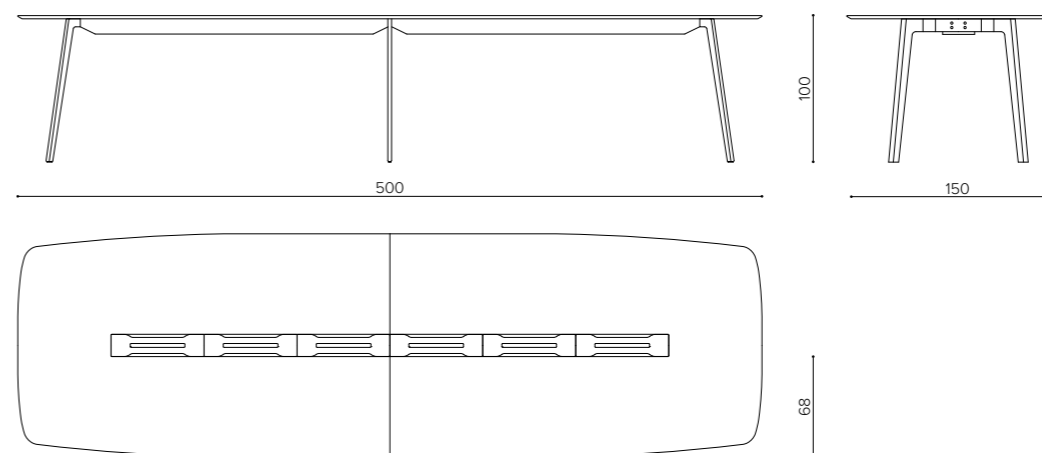

kg 155 mc 7,5

WI 22PL
side dividing panel for Wing tables depth 110 cm
pannello divisorio laterale per tavoli profondi 110cm
panneau de séparation latéral pour
tables Wing profondeur 110cm

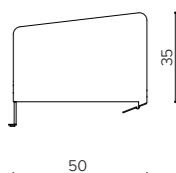

m 0,7 ☆ mq 1,19 📦 kg 1,8 🛠 mc 0,057

WI 32PL
side dividing panel for Wing tables depth 120cm
pannello divisorio laterale per tavoli profondi 120cm
panneau de séparation latéral pour
tables Wing profondeur 120cm

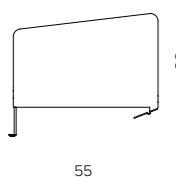

m 0,7 ☆ mq 1,2 📦 kg 2 🛠 mc 0,057

WI 45PL
side dividing panel for Wing tables depth 140cm
pannello divisorio laterale per tavoli profondi 140cm
panneau de séparation latéral pour
tables Wing profondeur 140cm

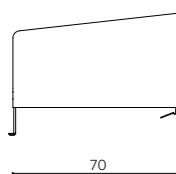

m 0,96 ☆ mq 1,6 📦 kg 2,5 🛠 mc 0,076

WI 50PL
side dividing panel for Wing tables depth 150cm
pannello divisorio laterale per tavoli profondi 150cm
panneau de séparation latéral pour
tables Wing profondeur 150cm

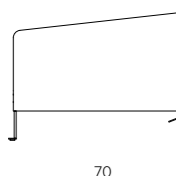

m 1,00 ☆ mq 1,65 📦 kg 2,7 🛠 mc 0,08

WI 22PC
central dividing panel for Wing tables width 220cm
pannello divisorio centrale per tavoli lunghi 220cm
panneau de séparation central pour
tables Wing longues 220cm

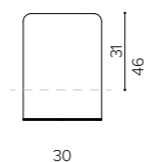

m 0,4 ☆ mq 0,74 📦 kg 1 🛠 mc 0,04

WI 30PC
central dividing panel for Wing tables width 300cm
pannello divisorio centrale per tavoli lunghi 300cm
panneau de séparation central pour
tables Wing longues 300cm

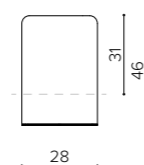

m 0,4 ☆ mq 0,74 📦 kg 1 🛠 mc 0,04

WI 32PC
central dividing panel for Wing tables width 320cm
pannello divisorio centrale per tavoli lunghi 320cm
panneau de séparation central pour
tables Wing longues 320cm

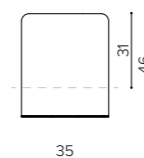

m 0,45 ☆ mq 0,8 📦 kg 1,2 🛠 mc 0,046

WI 45PC
central dividing panel for Wing tables width 450cm
pannello divisorio centrale per tavoli lunghi 450cm
panneau de séparation central pour
tables Wing longues 450cm

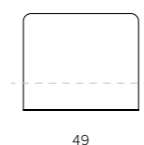

m 0,55 ☆ mq 0,93 📦 kg 1,5 🛠 mc 0,066

WI LB32
reading lamp for WI 320
lampada da lettura per WI 320
lampe de lecture pour WI 320

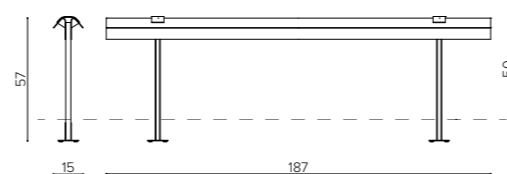

3000k led lamp, 2 mt. of cable, socket, on/off button
Lampada led da 3000k, 2 mt. di cavo, presa corrente, pulsante on/off
Lampe LED 3000k, 2 mt. de câble, prise de courant, bouton marche/arrêt

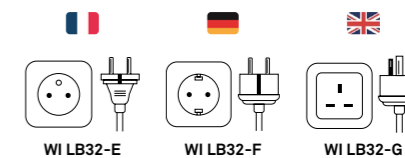

WI LB45
reading lamp for WI 450
lampada da lettura per WI 450
lampe de lecture pour WI 450

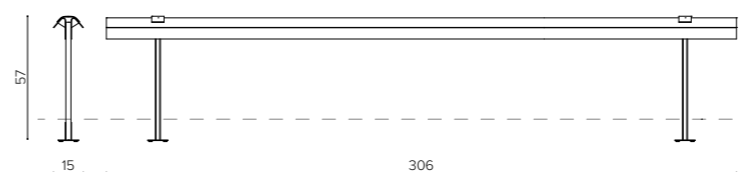

3000k led lamp, 2 mt. of cable, socket, on/off button
Lampada led da 3000k, 2 mt. di cavo, presa corrente, pulsante on/off
Lampe LED 3000k, 2 mt. de câble, prise de courant, bouton marche/arrêt

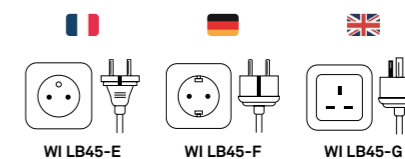

WI TW25
oakwood plate
piatto in legno
plaque de bois

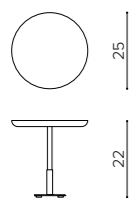

kg 1 mc 0,08

WOOD
LEGNO - BOIS



lacquered MDF
MDF laccato
MDF laqué

The standard finishing for the wooden parts is natural oakwood. Customized RAL colors are available upon request.

La finitura standard delle parti in legno è il rovere naturale. Su richiesta sono disponibili colorazioni customizzate su altre tinte RAL.

La finition standard des pièces en bois est en chêne naturel. Des couleurs RAL personnalisées sont disponibles sur demande.

WI TS35
iron plate
piatto in acciaio
plaque de acier

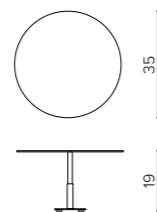

kg 1 mc 0,08

STEEL
ACCIAIO - ACIER



Click on the icon to see the standard RAL finishings for the steel bases on the dedicated page. Customized RAL colors finishings are available upon request.

Clicca sull'icona per vedere le finiture RAL standard delle basi in acciaio sulla pagina dedicata. Su richiesta sono disponibili colorazioni customizzate su altre tinte RAL.

Cliquez sur l'icône pour voir les finitions RAL standard des bases en acier sur la page dédiée. Des couleurs RAL personnalisées sont disponibles sur demande.

CABLE HOLDER
leather cable holder kit (4 pcs)
kit passacavi in pelle (4 pezzi)
kit porte-câbles en cuir (4 pièces)



WI PS01
multi socket power strip
multipresa
bloc multiprises

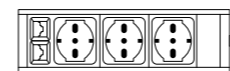

2x RJ45 + 3 Unel

WI PS02
multi socket power strip
multipresa
bloc multiprises

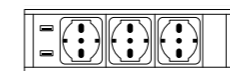

2x USB + 3 Unel

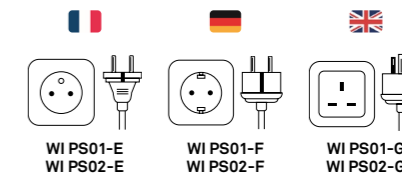

WI T00
cable management vertebra
vertebra passacavi
vertèbre de gestion des câbles

TOP OPTIONS

OPZIONI COPERCHI CANALE CENTRALE - OPTIONS DE COUVERTURE DU CANAL CENTRAL

shaped cover
coperchio sagomato
couvre-cable profilé

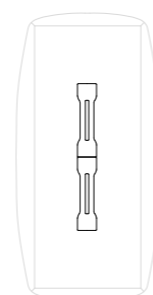

rectangular cover
coperchio rettangolare
couvre-cable rectangulaire

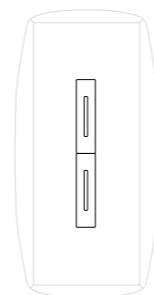

splitted cover
coperchio diviso
couvre-cable fendu

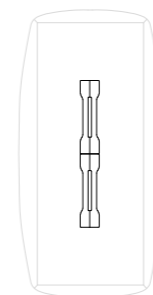

plain top
piano senza foro
plan sans trou

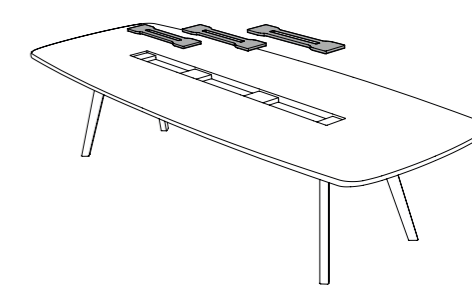

available for all tables
validi per tutti i tavoli - disponible pour toutes les tables

shaped cover provided as standard unless otherwise specified
coperchio sagomato fornito come standard se non diversamente specificato
couvre-cable profilé fourni en standard sauf indication contraire

CENTRAL CHANNEL DIMENSIONS

DIMENSIONI CANALE CENTRALE - DIMENSIONS DU CANAL CENTRAL

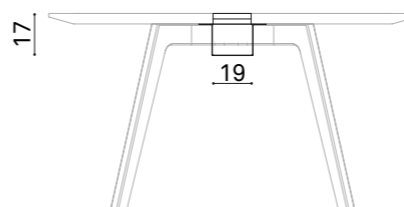

WOODEN TOP
PIANO IN LEGNO
PLATEAU EN BOIS

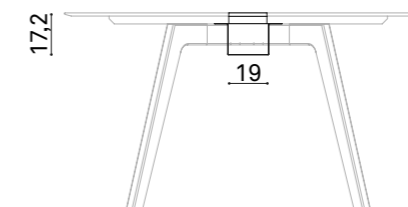

HPL TOP
PIANO IN HPL
PLATEAU EN HPL

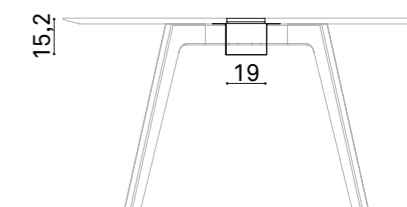

PLYWOOD TOP
PIANO IN MULTISTRATO
PLATEAU EN CONTREPLAQUÉ

UPHOLSTERY CATEGORIES

CATEGORIE RIVESTIMENTI - CATÉGORIES DE TISSUS D'AMEUBLEMENT

S	camira	GRAVITY	76% Polyester, 24% Recycled Polyester, non metallic dyestuffs 76% Poliestere, 24% Poliestere riciclato, coloranti non metallici 76% Polyester, 24% Polyester recyclé, colorants non métalliques
	camira	ERA	100% Polyester 100% Poliestere - 100% Polyester
	FIDIVI	LASER N	100% Polyester Trevira CS 100% Poliestere Trevira CS - 100% Polyester Trevira CS
	FIDIVI	ONE	100% Recycled polyester 100% Poliestere riciclato - 100% Polyester recyclé
T	FIDIVI	MAYA	100% Polyester Trevira CS 100% Poliestere Trevira CS - 100% Polyester Trevira CS
	FIDIVI	SEALIFE	100% Recycled Polyester 100% Poliestere riciclato - 100% Polyester recyclé
	FIDIVI	CORTE	100% Polyester Trevira CS 100% Poliestere Trevira CS - 100% Polyester Trevira CS
	SPRADLING®	VALENCIA	Vinyl / Urethane Topcoat Finitura in vinile / uretano - Revêtement de finition vinyle / uréthane
	camira	MAIN LINE FLAX	70% Virgin Wool, 30% Flax 70% Lana Vergine, 30% Lino - 70% Laine vierge, 30% Lin
	camira	MAIN LINE TWIST	75% Virgin Wool, 25% Flax 75% Lana Vergine, 25% Lino - 75% Laine vierge, 25% Lin
M	FIDIVI	LASER J & J FLASH	100% Polyester Trevira CS 100% Poliestere Trevira CS - 100% Polyester Trevira CS
	kvadrat	FIELD 2	100% Polyester Trevira CS 100% Poliestere Trevira CS - 100% Polyester Trevira CS
	Gabriel	FOCUS	100% New Zealand wool 100% lana della Nuova Zelanda - 100% laine de Nouvelle-Zélande
	Gabriel	FOCUS MELANGE	100% New Zealand wool 100% lana della Nuova Zelanda - 100% laine de Nouvelle-Zélande
	Gabriel	GRAIN	92% Post-consumer recycled polyester, 8% Polyester 92% Poliestere riciclato, 8% Poliestere 92% Polyester recyclé, 8% Polyester
F	camira	SYNERGY	95% Virgin Wool, 5% Polyamide 95% Lana Vergine, 5% Poliammide - 95% Laine vierge, 5% Polyamide
	mariosirtori	RICCIOLONE	56% Acrylic, 15% Polyester, 12% Viscose, 11% Cotton, 6% Flax 56% Acrilico, 15% Poliestere, 12% Viscosa, 11% Cotone, 6% Lino 56% Acrylique, 15% Poliestère, 12% Viscose, 11% Coton, 6% Line
	Gabriel	FOCUS ROYAL	100% New Zealand wool 100% Lana della Nuova Zelanda - 100% Laine de Nouvelle-Zélande
	kvadrat	REMIX 3	90% New wool (worsted), 10% Nylon 90% Lana vergine (pettinata), 10% Nylon - 90% Laine vierge (peignée), 10% Nylon
	FLUKSO	GORGEUS	50% PES FR - 50% TREVIRA® CS 50% PES FR - 50% TREVIRA® CS - 50% PES FR - 50% TREVIRA® CS
mariosirtori	MONTREAL	65% Wool, 24% Cotton, 6% Other Fibers, 5% Polyester 65% Lana, 24% Cotone, 6% Altre fibre, 5% Poliestere 65% Laine, 24% Coton, 6% Autres fibres, 5% Polyester	
L	kvadrat	TONUS 4	90% New wool, 10% Helanca 90% Pura lana vergine, 10% Helanca - 90% Pure laine vierge, 10% Helanca
	camira	CRAGGAN FLAX	85% Wool, 10% Flax, 5% Polyamide 85% Lana, 10% Lino, 5% Poliammide - 85% Laine, 10% Line, 5% Polyamide
P	DANI	PANAMA GENUINE LEATHER	Chrome tanned european bovine raw hides Pelle bovina europea ai sali di cromo - Cuir de bovin européenne avec sels de chrome
PX	elmo	BALTIQUE FULL GRAIN LEATHER	European bovine leather Pelle bovina europea - Cuir de bovin européen

OUTDOOR UPHOLSTERY CATEGORIES

CATEGORIE RIVESTIMENTI OUTDOOR - CATÉGORIES DE TISSUS D'AMEUBLEMENT OUTDOOR

M	SPRADLING®	MAGLIA	Vinyl / Urethane Topcoat Finitura in vinile / uretano - Revêtement de finition vinyle / uréthane
	RUBELLI	FIFTYSHADES	100% PL flame retardant 100% PL ignifugo - 100% PL ignifuge
L	RUBELLI	DIECIELODE	100% PL flame retardant 100% PL ignifugo - 100% PL ignifuge
	RUBELLI	FABTHIRTY	100% PL flame retardant 100% PL ignifugo - 100% PL ignifuge

OUTDOOR USE AND MAINTENANCE

USO E MANUTENZIONE PER L'OUTDOOR - UTILISATION ET MAINTENANCE POUR L'EXTÉRIUR



STEEL
METALLO/MÉTAL

Steel is used in the manufacture of metal products. This material galvanised and powder-coated, is ideal for outdoor use. Regarding products intended for seaside locations we recommend cleaning on a quarterly basis, with a cloth using water or mild detergents. During the winter period we recommend storing the furniture in closed, dry rooms in order to prevent condensation. In fact, although our products are suitable for outdoor use, during colder months the products should be stored in a closed, dry place in order to prevent moisture and seasonal frosts from affecting the finish.

Nella realizzazione dei prodotti metallici viene impiegato l'acciaio, il quale in seguito al processo di zincatura e di verniciatura a polveri, risulta ideale per l'utilizzo outdoor. Durante il periodo invernale consigliamo di conservare gli arredi in luoghi chiusi ed asciutti per evitare la formazione di condensa. Per i prodotti destinati a località marittime consigliamo con cadenza trimestrale una pulizia con un panno utilizzando acqua o detersivi non aggressivi. Nonostante i nostri prodotti siano adatti all'ambiente esterno, durante il periodo invernale è consigliato il ricovero dei prodotti in un luogo chiuso ed asciutto. In modo da evitare che l'umidità unita alle gelate stagionali possa in qualche modo intaccare le finiture.

L'acier est la matière première utilisée dans la fabrication de ces produits métalliques qui, après un processus de galvanisation et un revêtement de finition par poudre, sont idéaux pour une utilisation en extérieur. Pour les produits destinés à être utilisés en bord de mer, nous recommandons un nettoyage trimestriel avec un chiffon utilisant de l'eau ou des détergents doux. Bien que nos produits soient adaptés à un usage extérieur, nous recommandons de les stocker dans un endroit fermé et sec pendant l'hiver; ceci afin d'éviter que l'humidité combinée aux gelées saisonnières n'affecte d'une manière ou d'une autre les finitions.

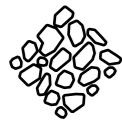

STONE
PIETRA/PIERRE

The stone tops are made of Marble or Quarella and they are ideal for the outdoor environment. Use a soft cloth with just water for daily cleaning. Avoid the use of aggressive abrasive sponges or steel wool pads. The furnishings made of stone such as marble and Quarella, during the first week of use will undergo a slight dulling due to contact with external elements. This is a natural phenomenon which does not affect the quality of the material. When the furniture is placed in seaside locations or swimming pools, cleaning with fresh water on a quarterly basis is recommended in order to avoid water corrosion due to salt build-up or chlorosis. Although our products are suitable for outdoor use, during colder months the products should be stored in a closed, dry place in order to prevent moisture and seasonal frosts from affecting the finish.

Materiale composito autoportante adatto all'ambiente Outdoor. Utilizzare un panno morbido con sola acqua per la pulizia quotidiana. In caso di necessità utilizzare detersivi non aggressivi. Evitare l'impiego di spugne abrasive o pagliette in acciaio. Nel caso di collocamento degli arredi in località marittime o piscine, si consiglia una pulizia trimestrale utilizzando acqua dolce per evitare principi di corrosione dovuti ad accumuli salini o clorosi. Nonostante i nostri prodotti siano adatti all'ambiente esterno, durante il periodo invernale è consigliato il ricovero dei prodotti in un luogo chiuso ed asciutto. In modo da evitare che l'umidità unita alle gelate stagionali possa in qualche modo intaccare le finiture.

Les dessus en pierre sont en marbre ou en quarella, idéaux pour une utilisation en extérieur. Utilisez un chiffon doux avec de l'eau uniquement pour le nettoyage quotidien. Évitez d'utiliser des détergents agressifs, des éponges abrasives ou des tampons de laine d'acier. Les meubles en pierre tels que le marbre et la Quarella, pendant la première semaine, subissent un léger ternissement dû au contact avec les éléments extérieurs. Il s'agit d'un phénomène naturel, qui n'affecte pas la qualité du matériau. Si le meuble est placé dans des stations balnéaires ou des piscines, nous recommandons un nettoyage trimestriel à l'eau douce pour éviter la corrosion due à l'accumulation de sel ou à la chlorose. Bien que nos produits conviennent à une utilisation en extérieur, il est recommandé, pendant la période hivernale, de stocker les produits dans un endroit fermé et sec, afin d'éviter que l'humidité combinée aux gelées saisonnières n'affecte d'une manière ou d'une autre la finition.



FABRICS
TESSUTI/TISSU

The fabrics used are naturally resistant to climatic elements, UV-resistant and anti-microbial. After heavy rainfall it is recommended to remove the cushions for quick drying and in order to prevent condensation. When the furniture is placed in seaside locations or swimming pools, cleaning with fresh water on a quarterly basis is recommended in order to avoid water corrosion due to salt build-up or chlorosis. Although our products are suitable for outdoor use, during colder months the products should be stored in a closed, dry place in order to prevent moisture and seasonal frosts from affecting the finish.

I tessuti impiegati sono naturalmente resistenti agli elementi climatici, resistenti ai raggi UV ed anti-microbici. A seguito di forti precipitazioni è consigliato rimuovere i cuscini per un'asciugatura rapida e prevenire la formazione di condensa. Nel caso di collocamento degli arredi in località marittime o piscine, si consiglia una pulizia trimestrale utilizzando acqua dolce per evitare principi di corrosione dovuti ad accumuli salini o clorosi. Nonostante i nostri prodotti siano adatti all'ambiente esterno, durante il periodo invernale è consigliato il ricovero dei prodotti in un luogo chiuso ed asciutto. In modo da evitare che l'umidità unita alle gelate stagionali possa in qualche modo intaccare le finiture.

Les tissus utilisés sont naturellement résistants aux éléments climatiques, résistants aux UV et antimicrobiens. Après de fortes pluies, il est toutefois conseillé de retirer les coussins pour un séchage rapide et pour éviter la formation de condensation. Si le mobilier est placé dans des stations balnéaires ou des piscines, nous recommandons un nettoyage trimestriel à l'eau douce pour éviter la corrosion due à l'accumulation de sel ou de chlore. Bien que nos produits soient adaptés à une utilisation en extérieur, il est recommandé de les stocker dans un endroit fermé et sec pendant la période hivernale, afin d'éviter que l'humidité combinée aux gelées saisonnières n'affecte d'une manière ou d'une autre les finitions.

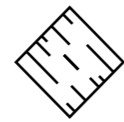

HPL
HPL/HPLR

Self-supporting composite material suitable for outdoor environment. Use a soft cloth with water only for daily cleaning. If necessary, use non-aggressive detergents. Please avoid using abrasive sponges or steel wool pads. When the furniture is placed in seaside locations or swimming pools, cleaning with fresh water on a quarterly basis is recommended in order to avoid water corrosion due to salt build-up or chlorosis. Although our products are suitable for outdoor use, during colder months the products should be stored in a closed, dry place in order to prevent moisture and seasonal frosts from affecting the finish.

Materiale composito autoportante adatto all'ambiente Outdoor. Utilizzare un panno morbido con sola acqua per la pulizia quotidiana. In caso di necessità utilizzare detersivi non aggressivi. Evitare l'impiego di spugne abrasive o pagliette in acciaio. Nel caso di collocamento degli arredi in località marittime o piscine, si consiglia una pulizia trimestrale utilizzando acqua dolce per evitare principi di corrosione dovuti ad accumuli salini o clorosi. Nonostante i nostri prodotti siano adatti all'ambiente esterno, durante il periodo invernale è consigliato il ricovero dei prodotti in un luogo chiuso ed asciutto. In modo da evitare che l'umidità unita alle gelate stagionali possa in qualche modo intaccare le finiture.

Matériau composite autoportant adapté à un usage extérieur. Utilisez un chiffon doux avec de l'eau uniquement pour le nettoyage quotidien. Si nécessaire, utilisez des détergents non agressifs. Évitez d'utiliser des éponges abrasives ou des tampons de laine d'acier. Si le mobilier doit être installé dans des stations balnéaires ou des piscines, nous recommandons un nettoyage trimestriel à l'eau douce pour éviter la corrosion due au sel ou au chlore. Bien que nos produits conviennent à une utilisation en extérieur, il est recommandé, pendant la période hivernale, de stocker les produits dans un endroit fermé et sec, afin d'éviter que l'humidité combinée aux gelées saisonnières n'affecte d'une manière ou d'une autre les finitions.

STANDARD STEEL RAL COLORS

COLORI RAL STANDARD PER ACCIAIO - COULEURS RAL STANDARD POUR L'ACIER

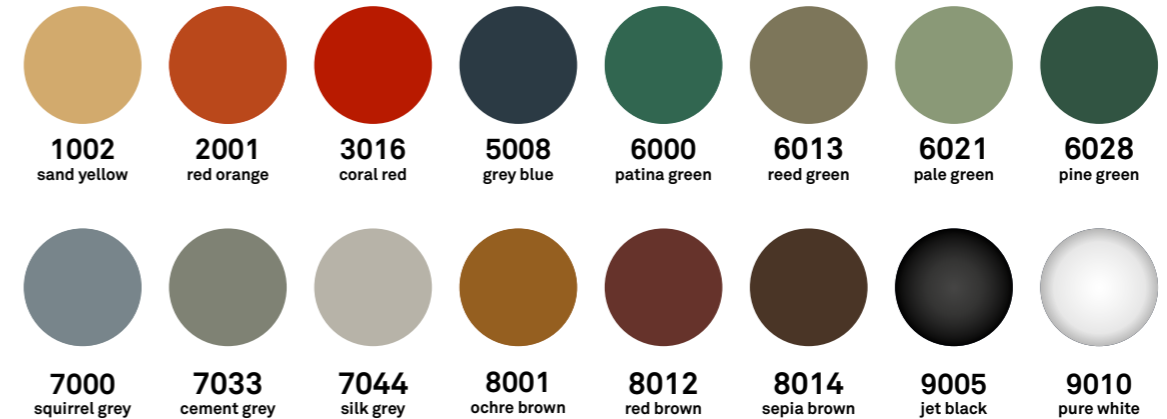

The standard finishings for the steel elements are the RAL shown. Customized RAL colors finishings are available upon request.

Le finiture standard degli elementi in acciaio sono i RAL mostrati. Su richiesta sono disponibili colorazioni customizzate su altre tinte RAL.

Les finitions standard des éléments en acier sont le RAL illustré. Des couleurs RAL personnalisées sont disponibles sur demande.



MATERIAL FINISHES AND COLOR SWATCHES

FINITURE MATERIALI E CAMPIONI COLORI - FINITIONS ET ÉCHANTILLONS COULEURS

DOWNLOAD

Click on the image above to download the material finishes and color swatches

Clicca sull'immagine per scaricare il pdf delle finiture dei materiali e dei campioni colori

Cliquez sur l'image associée pour télécharger les finitions et échantillons couleurs

